

Unmanned Fuel Station

Prof. BangalSwapnil. P.

Assistant Professor, Department of Electronics Engineering, P.R.E.C., Loni, India

Abstract: The petroleum items are one of the significant and uncommon manifestations of the nature. The best possible use and circulation is imperative assignment to survive these items. Our framework might be the main methodology towards security of petroleum items appropriation, for example, petrol, diesel, and lamp oil and others. "The basic and authorized utilization of GSM and RFID advances can give add up to security to appropriation of petroleum items!" this is our proposed. Basic pursuit framework and direct PC interface for the framework which encourages the record keeping of the appropriated fuel. Additionally the convenient and vigorous VB system will help to approved organization to control the dispersion of fuel entire over the locale or nation. In our framework the control unit and tanker unit are two main parts. The two frameworks which might far from each other can without much of a stretch correspond with each other. The security code in RFID label gave to the petrol pump get read by the per user and transmission of it to the control unit will organizations to make the correct database of different petrol pumps circulated over wide range. Additionally the circulation of the fuel is impractical until control unit gives the correct summon to the valve in tanker unit. In short the undertaking we have created is the fundamental connection of every above gadget; which will use to give security to the fuel dispersion and helps the information keeping of the conveyed fuel. The headway of the venture to expansive scale can help monetarily to the business in a roundabout way. The primary reason for our task fulfils every one of the requirements identified with secure circulation of the mechanical items.

Keywords: AT COMMANDS, GSM, GUI, LCD.

I. INTRODUCTION

21st century is appropriately kenneled as the digital world age on account of the increasing usage of web in the everyday exercises. Illustrations of these applications incorporate web saving money and financier, money administration, charge filling, mechanized petrol pump, medicinal field. To the extent mechanized petrol pump is concerned, a ton has as of now been done in this field. But as far as safety of Fuel pump is concerned we are still abaft the world. Leakage of petrol or any oil leads to a blast and purloining of petrol may lead to debacle. The purpose of our system is to provide an authentication to the user & control the aperture or closing of the tank valve according to amount inductively authorized. We will utilize GSM technology for this purport.

The framework will comprise of two units; one at tanker side which will screen ceaselessly the fuel level in the tank. The underlying flawless fuel level and ebb and flow fuel level will be displayed on LCD at front for driver convenience. Second is the RFID get together which will read the verification code of the petrol pump. The measure of fuel poured at specific petrol pump and petrol pump ID will be send to focal office through GSM systems.

A. Aim of the project

As we are venturing towards the 21st century, man is turning out to be extremely fastidious about security, with no special case for businesses. Sundry petroleum commercial ventures are turning out to be extremely fastidious about assembling and dispersion of their items. Early innovation addresses these imperatives, giving the substratum to authorize helpful cooperation to be produced. In this way the embedded security framework

using GSM and RFID methods is only sample of beginning innovation which will be giving the base to security of item conveyance and information continuing using electronic control.

B. Purpose

The indicate of this coordinating is to set up the extent of the undertaking regarding the real capacities, execution issues and specialized limitations. The coordination will give an assessment of the span of the item, the exertion required and the length of time. This arrangement will also consider the danger experienced amid the undertaking and the procedures for managing them. The organization will furthermore examine the point by point calendar of sundry subtasks inside of the task and withal the assets expected to perform them.

C. Brief History

In beginning days the petroleum commercial enterprises were conveying petrol using tankers to separate petrol pumps; which were unremarkably manual appropriation and was perfectly relies on upon man staunchness that was doing this employment. Presently a day industry are turning out to be extremely reliable about these things and attempting to midway control all the engenderment and circulation of items.

For the safe dissemination of items, businesses attempting to add to the nascent development security framework to accomplish their objective. However today petrol conveyance framework is has a few burdens in regards to with stilling of petrol, unapproved petrol offering by merchant, commixing of polluted and confused things in petro land other items.

II. THEORATICAL DETAILS AND ANALYSIS

The client inductively approving the fuel from the petroleum business will first call the business to pass on the essential. Organization will send the fuel by means of tanker to the petrol pump. Presently, our framework comes into subsistence in two expressions, one is set inside the tanker/transport and other is set at the circulating business itself. One unit which is set at tanker will screen never-endingly the fuel level in the tank. The underlying unblemished fuel level and flow fuel level will be shown on LCD at front for driver's settlement

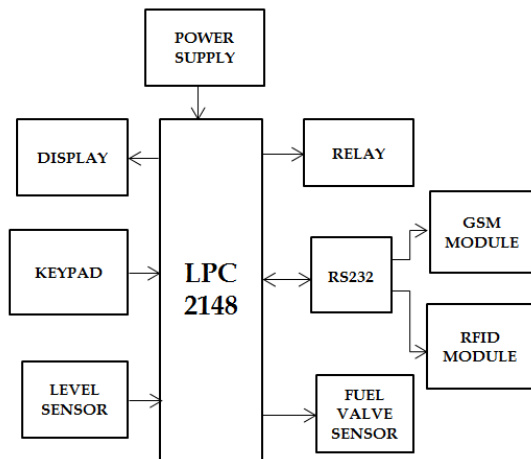

Fig. 1 Block Diagram Of Unmanned Fuel Station

The electronic valve is provided to keep the tanker opening block until it get the aperture order from the LPC2148. The RFID assembly reads the authentication code of the petrol pump by swapping the consumers tag over the RFID tagged at the petrol pump and send it to the control unit in order to update the database as well as to authenticate the customer who is inductively authorizing the petrol.



Fig. 2 Petrol Pump

On other hand at tanker unit side, the RFID system is associated to the microcontroller, relay electronic and level sensor valve assembly; where the RFID reader is used to identify the authenticated utilizer ID and send the information about level of fuel and utilizer ID number to the Control cabin Section. The borrower just needs to

convey the required amount of fuel to be poured into the tanker. On the other hand the control cabin comprises of other GSM unit which receives the information from tanker unit and interface sequentially to personal computer so as to edit that data for further work of replication.

On getting the interrupt from the control cabin unit, the valve takes action consequently. The Microcontroller perpetually sense the fuel level utilizing level sensor and it keeps the valve open until it reaches the quantity to be distributed by reducing the counter. Here the initial fuel level as well as the caliber of fuel after distribution gets exhibit on the LCD screen. Additionally, the control.



Fig. 3 Outdoor Payment Terminal OPT 240

Unit updates the record by recording the time and date of distribution and whether transaction is complete or not? Thus our system provides whole and central control on petrol distribution utilizing simple RFID and GSM techniques.

III. EXPLORING WORKING OF THE SYSTEM

For Tanker unit-

- 1) Start.
- 2) Check the status of GSM modem using AT
- 3) Commands.
- 4) Check the status of level sensor.
- 5) Display level of fuel.
- 6) Check status of RFID reader.
- 7) If swap against tag, display corresponding ID.
- 8) Send the ID to central unit.
- 9) Check for response from central unit.
- 10) Open the valve relay.
- 11) Fuel is discharged
- 12) Close the valve relay.
- 13) Display the remaining amount on LCD
- 14) Message is received to customer,
- 15) Again go to step 2 and repeat up to step 14.
- 16) Stop.

For Control Unit-

- 1) Start.
 - 2) Firstly customer will put across the RFID provided to him and then the quantity of fuel required.
 - 3) Keep the data of the customer in the forms provided in the sequence such as name, location, ID and amount required.
 - 4) Take the information from tanker unit.
 - 5) Receive user ID and other data from GSM.
 - 6) Match the received id with present id.
 - 7) If match, send the message to the tanker unit.
 - 8) Again follow step 4 to 6.
 - 9) Stop
- 3) In day to day life we can visually perceive that di-hydrogen monoxide distribution in summer is withal one of the quandaries in front of India. So it is possible to keep control on di-hydrogen monoxide distribution in particular area.
 - 4) The agricultural products like vegetables as well as processed fruits and its sub products may be securely distributed to the market utilizing the same system we proposed.
 - 5) Withal it is possible to keep record of the distributed products to the market; which is commercially most consequential for the industries.

IV. INTERFACING

Rudimental requisites for interfacing:

- Power supply 12V, 5V.
- GSM module with active SIM.
- DB9 connector for GSM and PC connection with our system.
- RFID reader with standard reading format.
- Passive tags for utilizer identification.
- Resistive /RF level sensor.

Attestation Exhibit with felicitous resolution.

V. ADVANTAGES AND LIMITATIONS

A. Advantages

- 1) This system has simple components and simple construction of them on circuit.
- 2) It is possible to implement this system on minuscule board space withal.
- 3) GSM system utilized in our project provides expeditious data communication over long distance withal.
- 4) RFID system avails us to provide the maximum security to authenticate the utilizer at minimum cost.
- 5) It requires very less power supply i.e. from 5V to 12 V only, which is facilely available.
- 6) Withal as it provides the central control on petrol distribution, thus there is no problem related to stilling or to transmute the record of distributed fuel.
- 7) Easy to handle for distribution.

B. Limitations

This system may suffer at remote area where there is quandary with GSM range.

Additionally the assailment from hackers may engender quandary but utilizing high standard of encryption and availing GSM transciever widely, one may overcome these constraints

VI. APPLICATIONS AND FUTURE SCOPE

- 1) In petroleum products distribution our system probes for the control on product larcenies which is the most earnest quandary for the manufacturing industries.
- 2) It is withal possible to implement the same system for milk processing industries while distributing the milk and its products to the market.

VII. PRACTICAL RESULTS

Party A has requested for the 50 liter of petrol, the database Party B get recorded. Swap the RFID tag against reader, keeping the position of the caliber sensor at the highest possible position, the RFID number and level of fuel get exhibited. Now Party B got the SMS which includes RFID number of Party A. As soon as the message received at the Party A, the relay get opened and the exhibit start to show the decremting fuel level since Valve decreases its position. As the valve reaches the position by pouring the particular fuel, it will get automatically turn OFF.

1.



2.



3.



4.



VIII. CONCLUSION

In the world of electronics it is consequential to develop the incipient technology to make secure the distribution of fuel and keeping record of the same fuel with sanction of utilizer. Our project is one conception which can transmute the face of today manual system of distribution and data keeping. The total central access of all these activities provide the correct approach toward security and economical desideratum of the industries since industry itself can control distribution as well as keep the record of the same fuel from thousands of miles seated in office. Additionally there is no option for the petrol pump or distributor to issue the fuel illicitly that is total faithfulness of both the sides will get maintained. In short, this project

probably can be implemented for the utilization of other tasks other than petrol distribution, on astronomically immense scale to achieve sundry goals of industries.

REFERENCES

- [1]. Frensel- communication electronics principles and applications- (3rd edition)- Tata McGraw Hill- -tenth print 2007-page no:505 to 506(for RFID)
- [2]. Ronald
- [3]. J.Tocc- Digital system (6th edition) - page no. 744 to 776.(for microcontroller interfacing)
- [4]. Kenneth.J.Ayala-The 8051 microcontroller architecture, programming and application (2nd edition) - 1997.(for microcontroller, LCD, ADC,MAX232 and assembly language reference)
- [5]. Patrik Naughton, Herbertschild -The complete reference of Java(3rd edition)- april 2000 (for JAVA basics)
- [6]. www.wireless.com/security.htm
- [7]. S. K. Singh, —Industrial Instrumentation & Control Tata McGraw Hill, .246.

BIOGRAPHY



Mr. Bangal Swapnil was born in Sangamner, Maharashtra, India, in 1987. He received the B.E. degree in Electronics and Telecommunication Engineering from the Savitribai Phule Pune University, Pune, India, in 2011, and Received the M.E. degree in E&TC (VLSI & Embedded System) from Savitribai Phule Pune University, in 2015.